

A

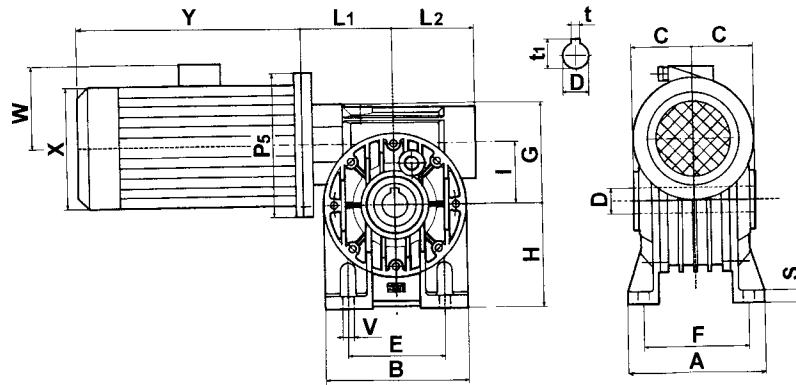

B

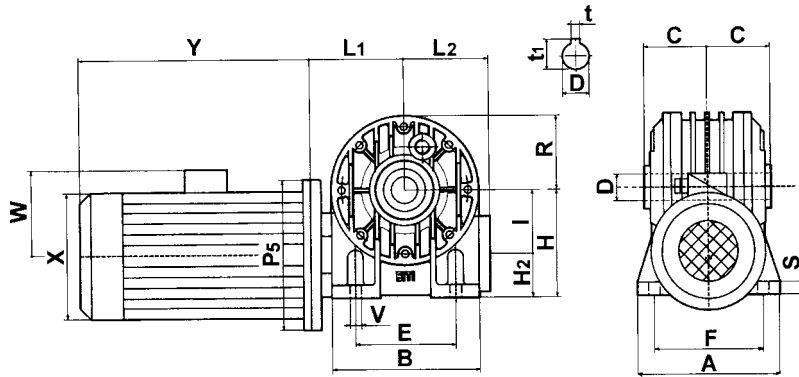

V

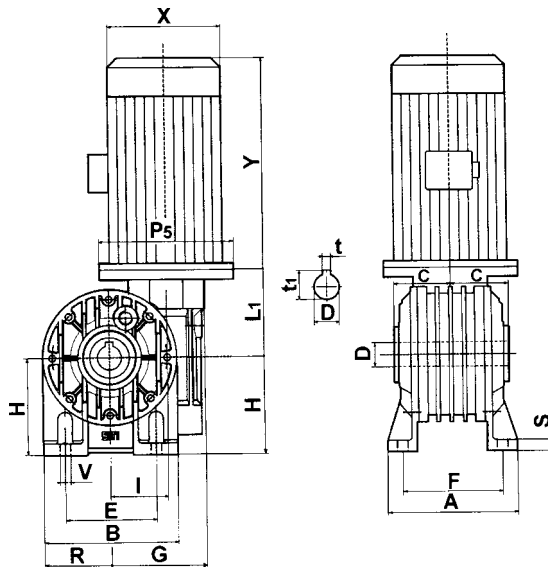

	L ₁	L ₂	G	R	A	B	E	F	V	H	H ₁	H ₂	C	S	D _{H7}	t	t ₁	P ₅
40	(•)	57	70	48	100	96	70	84	7	71	111	31	41	8	19	6	21,8	(•)
50	(•)	67	84	56	114	112	85	96	9	85	135	35	49	10	24	8	27,3	(•)
60	(•)	80	99	75	137	140	95	111	11	100	160	40	60	12	25	8	28,3	(•)
70	(•)	86	117	81	141	156	120	115	11	115	185	45	60,5	12	28	8	31,3	(•)

X, Y, W Vedere tabelle motori elettrici
(•) Vedere pag. 134

X, Y, W See electric motor table
(•) See page 134

X, Y, W Siehe Motortabelle
(•) Siehe Seite 134

Flange riportate per I - MI 40 ÷ 70

Nei riduttori a vite senza fine (grandezza 40, 50, 60, 70), le flange di uscita tipo "F" e "FBR" sono state modificate e trasformate in flange modulari riportate ovvero, anziché essere costruite in un sol pezzo per montaggio diretto sul corpo del riduttore, esse sono ora globalmente costruite in due parti.

Sulla versione base del riduttore, tipo "FP" (flangia piatta), possono essere direttamente collegate tramite accoppiamento con viti e flange riportate tipo "F", o rispettivamente "FBR".

Questa soluzione modulare, che non altera l'intercambiabilità globale, rende agevole la trasformazione da una versione all'altra, o da versione destra a versione sinistra.

Le stesse soluzioni si applicano anche sugli "MI".

Modular style output flanges I - MI 40 ÷ 70

In the wormgearboxes (sizes I 40, I 50, I 60 and I 70), the type "F" and "FBR" have been modified and have become modular flanges made in two parts, i.e. instead of being a single piece, they are such to be fitted on a common flange (the "FP", flat flange type), which is now the standard version of the wormgearbox. Therefore, on the "FP" version as a common basis, "F" or "FBR" modular flanges can be fitted easily through a bolt connection. This modular construction, which does not affect in any way the interchangeability of each gearbox version as assembly, makes easy to change from one version to another one, to modify a right to a left execution.

Same solutions apply also to "MI".

Modulare flansche I - MI 40 ÷ 70

Die Abtriebsflansche der Typen "F" und "FBR" bei den Schneckengetrieben der Größen 40, 50, 60, 70 wurden in modulare Flansch aus zwei Teilen umgeändert, so daß der jeweilige Flansch auf die Ausführung FP (Grundtyp) montiert wird. An der Basisversion des Getriebes, Typ "FP" (Flachflansch), können die modularen Flansch "F" oder "FBR" einfach mittels Schrauben befestigt werden.

Diese Konstruktion erleichtert den Umbau sowohl von einer Ausführung in eine andere, als auch von der rechten in die linke Abtriebsflanschlage.

Die allgemeine Austauschbarkeit mit alten Lösungen bleibt erhalten.

Selbe Lösungen sind gültig auch für "MI".

F

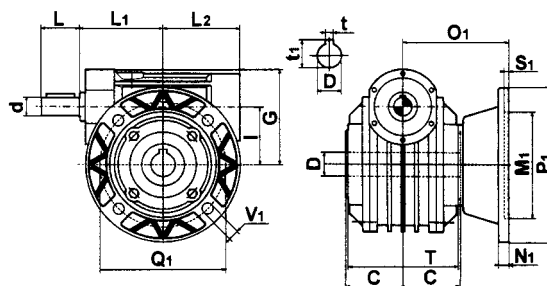

FBR

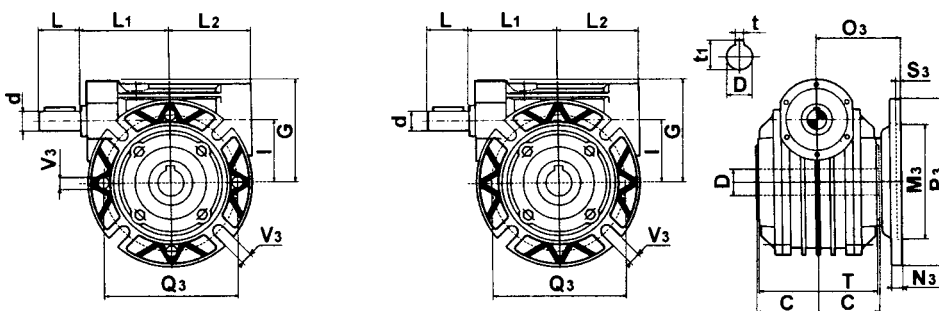

	L	L ₁	L ₂	C	T	G	d J6	D H7	Q ₁	M ₁ G6	P ₁	O ₁	N ₁	S ₁	V ₁	Q ₃	M ₃ G6	P ₃	O ₃	N ₃	S ₃	V ₃	t	t ₁
40	23	63	57	41	77	70	11	19	115	95	140	82	11	4	9	100	80	120	60	8	3	9	6	21,8
50	30	73	67	49	93	84	14	24	130	110	160	92	11	4	10	115	95	140	75	10	4	10	8	27,3
60	40	86	80	60	104	99	19	25	165	130	200	96,5	12	4	11	130	110	160	76	11	5	10	8	28,3
70	40	87	86	60,5	114	117	19	28	165	130	200	111,5	12	5	13	130	110	160	85	12	5	11	8	31,3

I 40 ÷ 70 - FP

I 40 ÷ 70 - FP

I 40 ÷ 70 - FP

FP

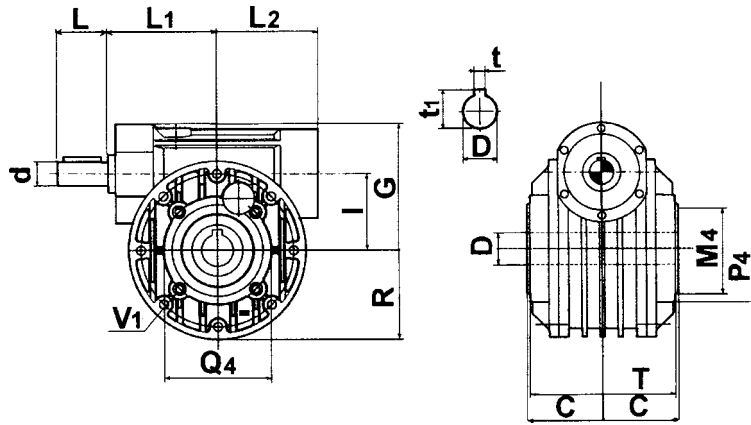

	d_{j6}	L	L ₁	L ₂	G	R	I	T	C	Q ₄	P ₄	M4 _{g6}	D _{H7}	t	t ₁	V ₁
40	11	23	63	57	70	48	40	77	41	65	72	50	19	6	21,8	M6
50	14	30	73	67	84	56	50	93	49	75	88	60	24	8	27,3	M6
60	19	40	86	80	99	70	60	104	60	85	105	70	25	8	28,3	M8
70	19	40	87	86	117	78	70	114	60,5	100	115	80	28	8	31,3	M8

MI 40 ÷ 70 - FP

MI 40 ÷ 70 - FP

MI 40 ÷ 70 - FP

FP

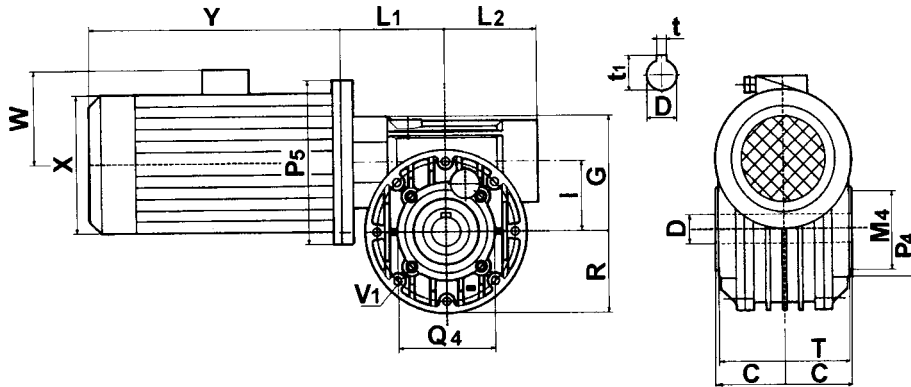

	L ₁	L ₂	G	R	I	T	C	Q ₄	P ₄	M4 _{g6}	D _{H7}	t	t ₁	V ₁	P ₅
40	(•)	57	70	48	40	77	41	65	72	50	19	6	21,8	M6	(•)
50	(•)	67	84	56	50	93	49	75	88	60	24	8	27,3	M6	(•)
60	(•)	80	99	70	60	104	60	85	105	70	25	8	28,3	M8	(•)
70	(•)	86	117	78	70	114	60,5	100	115	80	28	8	31,3	M8	(•)

X, Y, W Vedere tabelle motori elettrici
(•) Vedere pag. 134

X, Y, W See electric motor table
(•) See page 134

X, Y, W Siehe Motortabelle
(•) Siehe Seite 134