

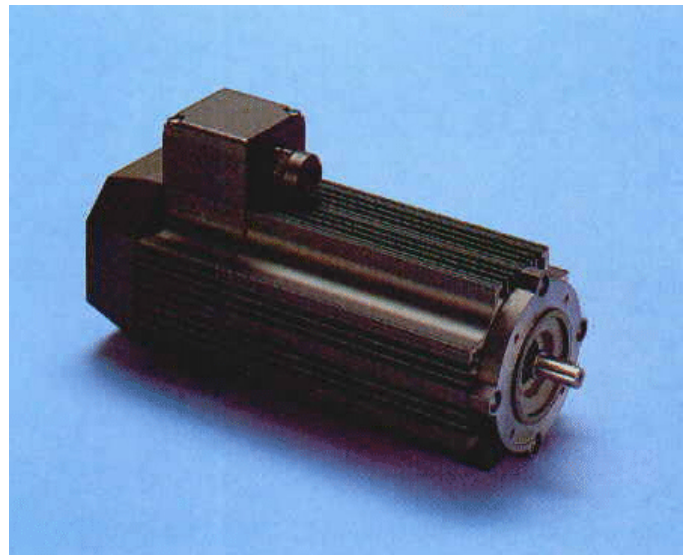

Industrialtecnoelettrica S.r.l.



motori in corrente continua a magneti permanenti
permanent magnet direct current motors

serie Q6

DATI MOTORE Motor ratings	SIMBOLI Symbols	UNITA' Units	SERIE Serie										
			Q6S										
COPPIA ALLA VELOCITA' NOM. Torque at rated speed	Cn	Nm	0.6					0.6					
VELOCITA' NOMINALE Rated speed	Nn	RPM	2000					3000					
POTENZA NOMINALE Rated output	Pu	W	125					190					
TENSIONE NOMINALE Rated voltage	Vn	V	170	90	48	24	12	170	90	48	24	12**	
CORRENTE NOMINALE Rated current	In	A	1	1.9	3.5	7.8	15	1.4	2.75	5.2	10.4	20	
COPPIA DI PICCO Peak torque	Cp	Nm	2.4	2.4	2.4	2.4	2.4	2.4	2.4	2.4	2.4	2.4	
CORRENTE DI PICCO Peak current	Ip	A	4	7.6	14	31.2	60	5.6	11	20.8	41.6	80	
RENDIMENTO Efficiency	η	%	75	73	73	69	69	80	77	77	76	71	
DATI MECCANICI Mechanical data													
INERZIA ROTORE Rotor inertia	J	Kg m ²	0.00031					0.00031					
MAX. ACCELERAZ. TEORICA Max theoretical acceleration	α	rad/ sec ²	7750					7750					
CARICO ASSIALE MAX Max axial load	Fa	N	119					119					
CARICO RADIALE MAX Max radial load	Fr	N	382					382					
VENTILAZIONE Ventilation			AUTOVENTILATO ESTERNO External self ventilation					AUTOVENTILATO ESTERNO External self ventilation					
GRADO DI PROTEZIONE Protection (IEC 34.5)		IP	54					54					
PESO Weight	G	Kg	4.3					4.3					
DATI ELETTRICI Winding data													
COSTANTE DI TEMPO TERMICA Thermal time constant	Tt	min	45					45					
COSTANTE DI TEMPO ELETT. Electrical time constant	Te	ms	3.2	2.8	2.3	1.9	2.9	3.4	3.1	2.4	2.6	1.6	
RESISTENZA D'ARMATURA Armature resistance	Rm	Ohm	28	9.5	3.3	1	0.14	13.8	5.1	1.5	0.34	0.13	
INDUTTANZA D'ARMATURA Armature inductance	La	mH	90	27	7.6	1.9	0.4	46.6	15.7	3.6	0.9	0.21	
CLASSE ISOLAMENTO Insulation class			F					F					
FATTORE DI SERVIZIO Duty			S1					S1					
FATTORE DI FORMA Form factor			1					1					
TEMPERATURA AMBIENTE Ambient temperature		°C	25					25					
ALTEZZA Height		m	1000					1000					
TOLLERANZE Tolerances		%	±5					±5					

** Servizio intermittente Intermittent duty

Altre tensioni a richiesta Other voltages on request

B3

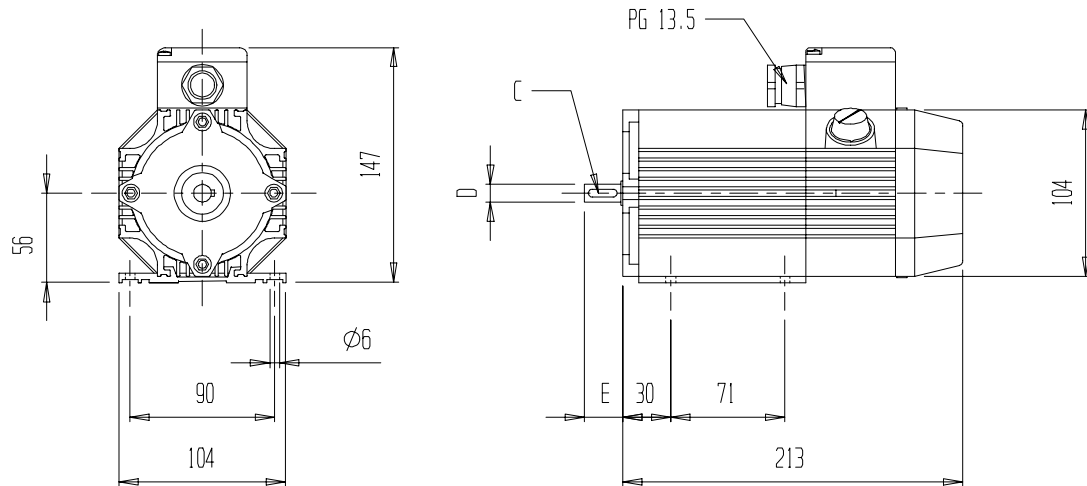

SIZE	D	E	C
MEC 56	9	20	3x3x15
MEC 63	11	23	4x4x18

**B14
M56**

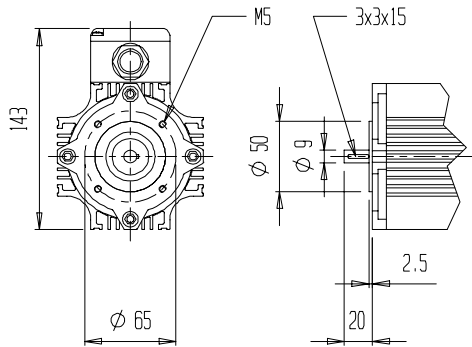

**B14
M63**

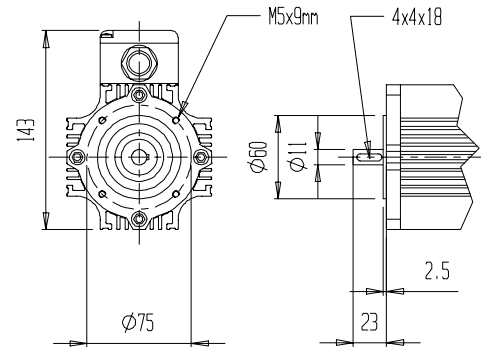

**B5
M63**

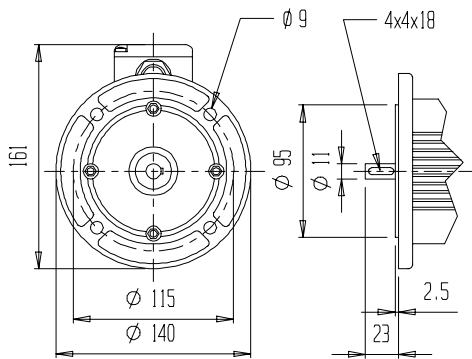

DATI MOTORE Motor ratings	SIMBOLI Symbols	UNITA' Units	SERIE Serie										
			Q6M										
COPPIA ALLA VELOCITA' NOM. Torque at rated speed	Cn	Nm	1.2					1.2					
VELOCITA' NOMINALE Rated speed	Nn	RPM	2000					3000					
POTENZA NOMINALE Rated output	Pu	W	260					380					
TENSIONE NOMINALE Rated voltage	Vn	V	170	90	60	48	24**	170	90	60	48	24**	
CORRENTE NOMINALE Rated current	In	A	2	3.7	5.5	7.1	15.5	2.8	5.3	8.1	9.9	22	
COPPIA DI PICCO Peak torque	Cp	Nm	4.8	4.8	4.8	4.8	4.8	4.8	4.8	4.8	4.8	4.8	
CORRENTE DI PICCO Peak current	Ip	A	8	14.8	22	28.4	62	11.2	21.2	32.8	39.6	88	
RENDIMENTO Efficiency	η	%	79	77	77	76	72	80	79	78	77	72	
DATI MECCANICI Mechanical data													
INERZIA ROTORE Rotor inertia	J	Kg m ²	0.00066					0.00066					
MAX. ACCELERAZ. TEORICA Max theoretical acceleration	α	rad/ sec ²	7280					7280					
CARICO ASSIALE MAX Max axial load	Fa	N	119					119					
CARICO RADIALE MAX Max radial load	Fr	N	382					382					
VENTILAZIONE Ventilation			AUTOVENTILATO ESTERNO External self ventilation					AUTOVENTILATO ESTERNO External self ventilation					
GRADO DI PROTEZIONE Protection (IEC 34.5)		IP	54					54					
PESO Weight	G	Kg	6.1					6.1					
DATI ELETTRICI Winding data													
COSTANTE DI TEMPO TERMICA Thermal time constant	Tt	min	45					45					
COSTANTE DI TEMPO ELETT. Electrical time constant	Te	ms	3.3	2.6	2.2	2	2.15	2.95	2.3	1.6	1.8	1.3	
RESISTENZA D'ARMATURA Armature resistance	Rm	Ohm	11.7	4.4	2.1	1.2	0.28	6.1	2.05	1.4	0.8	0.24	
INDUTTANZA D'ARMATURA Armature inductance	La	mH	38	11.2	4.7	2.5	0.6	18	4.7	2.2	1.4	0.3	
CLASSE ISOLAMENTO Insulation class			F					F					
FATTORE DI SERVIZIO Duty			S1					S1					
FATTORE DI FORMA Form factor			1					1					
TEMPERATURA AMBIENTE Ambient temperature		°C	25					25					
ALTEZZA Height		m	1000					1000					
TOLLERANZE Tolerances		%	±5					±5					

** Servizio intermittente Intermittent duty

Altre tensioni a richiesta Other voltages on request

B3

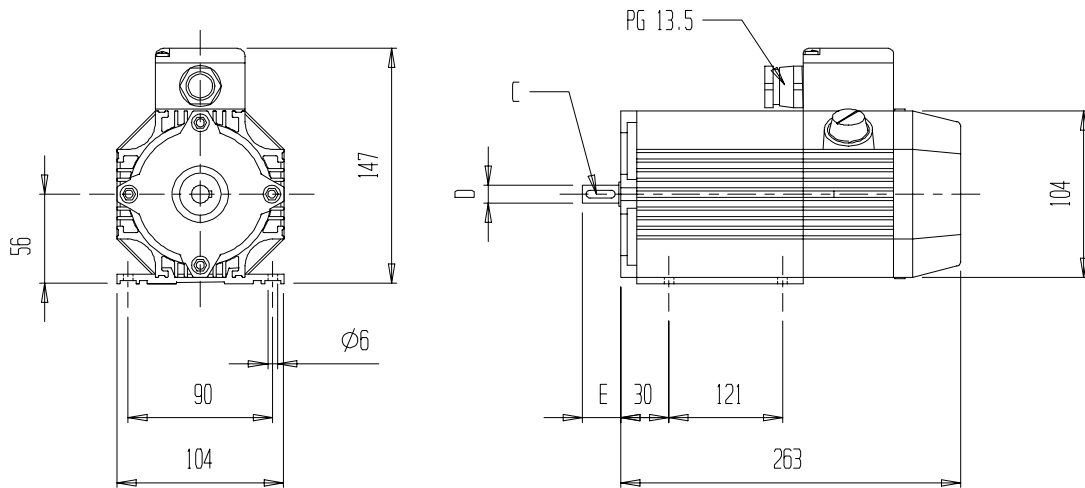

SIZE	D	E	C
MEC 63	11	23	4x4x18
MEC 71	14	30	5x5x25

**B14
M63**

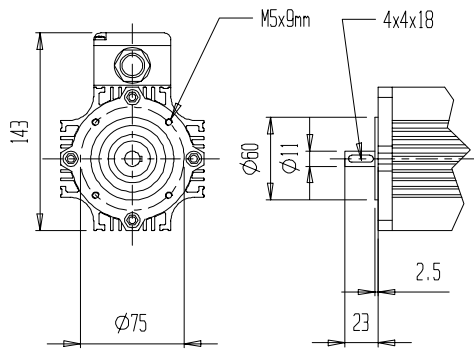

**B5
M63**

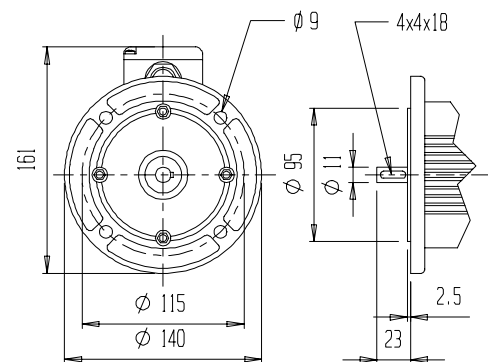

**B5
M71**

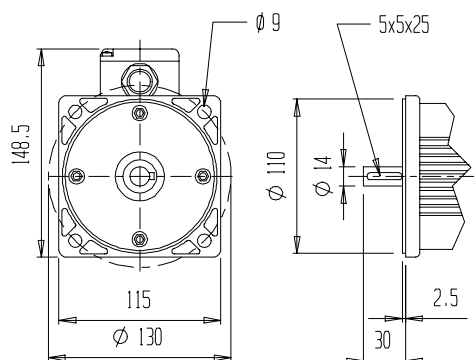

DATI MOTORE Motor ratings	SIMBOLI Symbols	UNITA' Units	SERIE Serie									
			Q6L									
COPPIA ALLA VELOCITA' NOM. Torque at rated speed	Cn	Nm	1.6					1.6				
VELOCITA' NOMINALE Rated speed	Nn	RPM	2000					3000				
POTENZA NOMINALE Rated output	Pu	W	330					500				
TENSIONE NOMINALE Rated voltage	Vn	V	170	90	60		170	90	60			
CORRENTE NOMINALE Rated current	In	A	2.5	4.6	6.7		3.7	7	10.6			
COPPIA DI PICCO Peak torque	Cp	Nm	6.4	6.4	6.4		6.4	6.4	6.4			
CORRENTE DI PICCO Peak current	Ip	A	10	18.4	26.8		14.8	28	42.4			
RENDIMENTO Efficiency	η	%	79	78	78		79	79	77			
DATI MECCANICI Mechanical data												
INERZIA ROTORE Rotor inertia	J	Kg m ²	0.00101					0.00101				
MAX. ACCELERAZ. TEORICA Max theoretical acceleration	α	rad/ sec ²	6350					6350				
CARICO ASSIALE MAX Max axial load	Fa	N	119					119				
CARICO RADIALE MAX Max radial load	Fr	N	382					382				
VENTILAZIONE Ventilation			AUTOVENTILATO ESTERNO External self ventilation					AUTOVENTILATO ESTERNO External self ventilation				
GRADO DI PROTEZIONE Protection (IEC 34.5)		IP	54					54				
PESO Weight	G	Kg	7.9					7.9				
DATI ELETTRICI Winding data												
COSTANTE DI TEMPO TERMICA Thermal time constant	Tt	min	45					45				
COSTANTE DI TEMPO ELETT. Electrical time constant	Te	ms	3	2.2	2.8		2.3	2.7	1.4			
RESISTENZA D'ARMATURA Armature resistance	Rm	Ohm	8.2	2.6	1.1		5	1.27	0.9			
INDUTTANZA D'ARMATURA Armature inductance	La	mH	25.2	5.6	3.1		11.5	3.4	1.25			
CLASSE ISOLAMENTO Insulation class			F					F				
FATTORE DI SERVIZIO Duty			S1					S1				
FATTORE DI FORMA Form factor			1					1				
TEMPERATURA AMBIENTE Ambient temperature		°C	25					25				
ALTEZZA Height		m	1000					1000				
TOLLERANZE Tolerances		%	±5					±5				

** Servizio intermittente Intermittent duty

Altre tensioni a richiesta Other voltages on request

B3

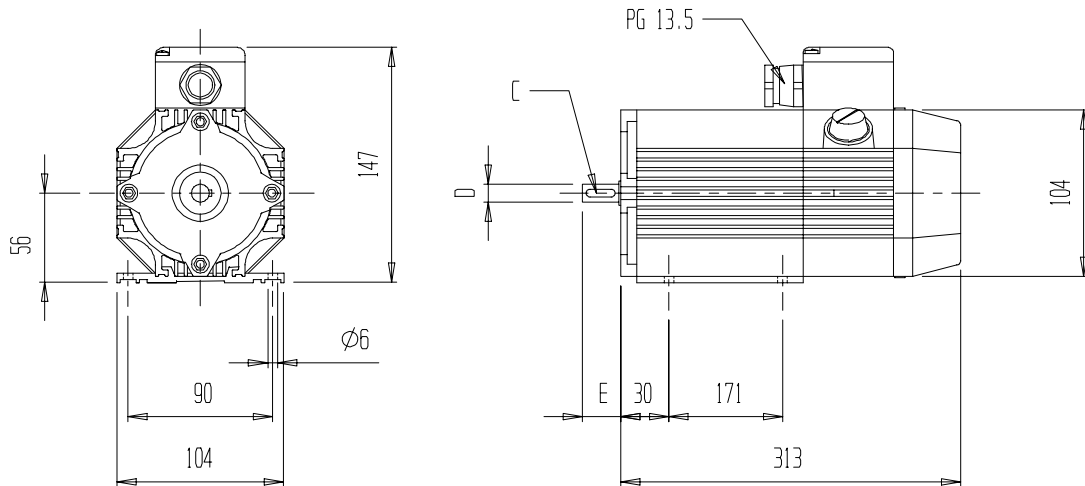

SIZE	D	E	C
MEC 63	11	23	4x4x18
MEC 71	14	30	5x5x25

**B14
M63**

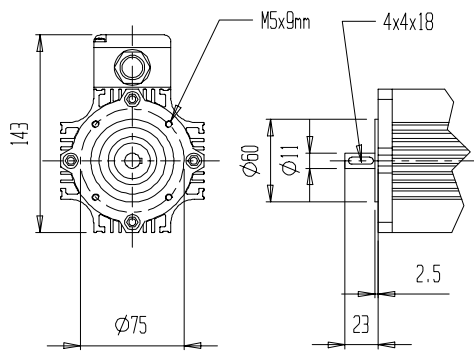

**B5
M63**

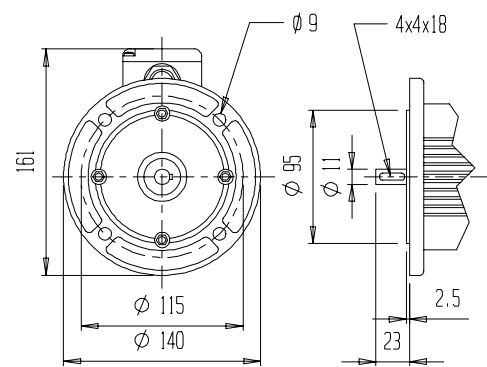

**B5
M71**

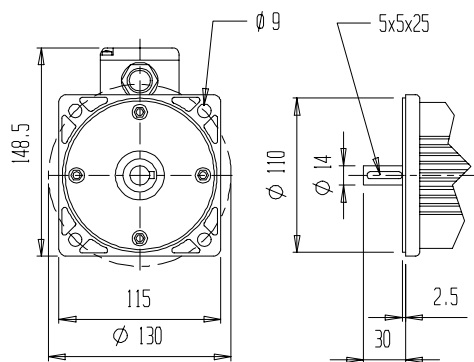

OPZIONI **Optionals**

SERIE Q6 Serie

ALTERNATORE TACHIMETRICO
Alternator

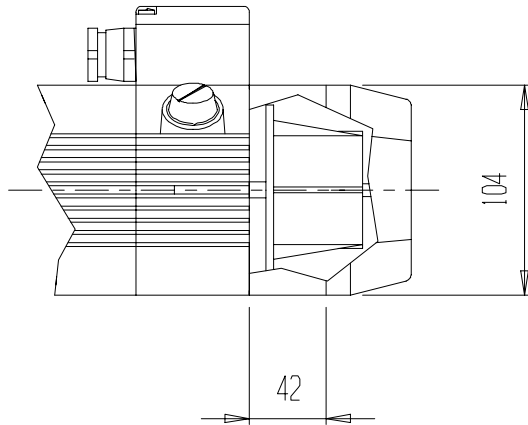

costante di tens. voltage constant	24 V/KRPM
max velocita' max speed	10000 RPM
corrente nominale rated current	5 mA
max corrente max current	100 mA

DINAMO TACHIMETRICA 4 POLI
Tacho generator 4 poles

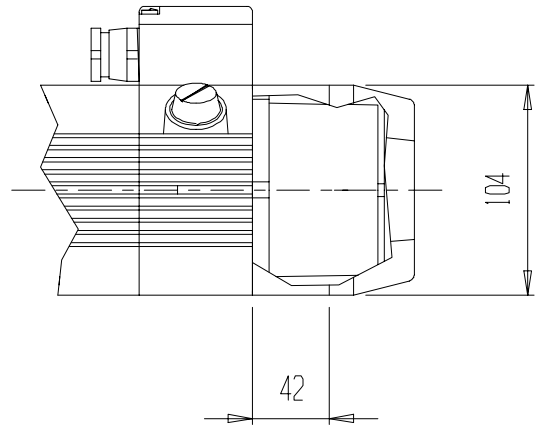

costante di tens. voltage constant	10 V/KRPM
ondulazione di picco ripple	1.6 %
linearita' linearity (6000 RPM)	0.5 %
N° poli N°poles	4

FRENO
Brake

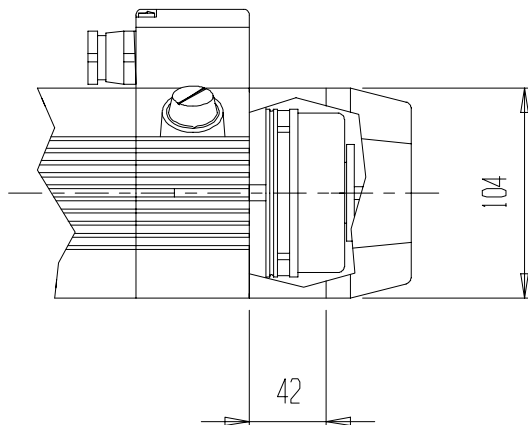

coppia statica static torque	6 Nm
tensione alim. pwr supply voltage	24 - 190 V cc
corrente current	0.85 - 0.1 A
potenza assorbita input power	20 W

DINAMO TACHIMETRICA 2 POLI
Tacho generator 2 poles

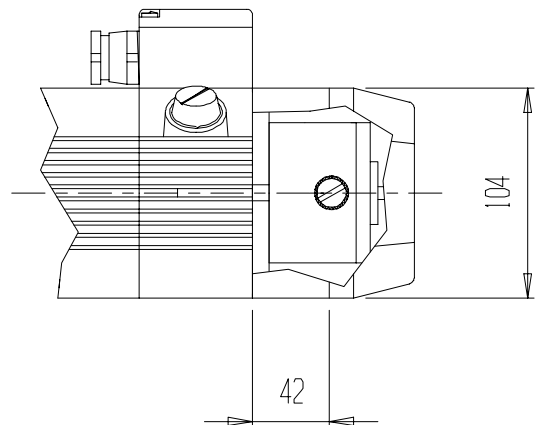

costante di tens. voltage constant	10 V/KRPM
ondulazione di picco ripple	≤10 %
linearita' linearity (5000 RPM)	8 %
N° poli N° poles	2

Q **6** **S** **30** **17** **02** **9**

OPZIONI Optional	
0	D.T 2 POLI T.G 2 Poles
1	D.T 4 POLI T.G 4 Poles
4	FRENO Brake
7	ALTERNATORE Alternator
8	ENCODER
9	SOLO MOTORE Only motor
X	SPECIALI Special

FORMA COSTRUTT. Construction form	
01	B14 M56
02	B5 M71
03	B14 M63
04	B5 M63
07	B3 M56
08	B3 M63
09	B3 M71
11	B3-B14 M56
12	B3-B5 M71
13	B3-B14 M63
14	B3-B5 M63

TENSIONE Voltage	
12	12 V
24	24 V
48	48 V
60	60 V
90	90 V
17	170 V

N° GIRI RPM	
20	2000 RPM
30	3000 RPM

TAGLIA MOTORE Motor lenght	
S	CORTO Short
M	MEDIO Medium
L	LUNGO Long

TIPO MOTORE Motor type	
3	SERIE SPECIALE (VENTILAZIONE NATURALE) Special serie (natural ventilation)
6	AUTOVENTILATO ESTERNO External autoventilated

SERIE MOTORE Motor serie	
Q	QUADRIMOT